

Abrasive Jet Machining

INTRODUCTION

Abrasive water jet machine tools are suddenly being a hit in the market since they are quick to program and could make money on short runs. They are quick to set up, and offer quick turn-around on the machine. They complement existing tools used for either primary or secondary operations and could make parts quickly out of virtually out of any material. One of the major advantage is that they don't heat the material. All sorts of intricate shapes are easy to make. They turn to be a money making machine.

So ultimately a machine shop without a water jet, is like a carpenter with out a hammer. Sure the carpenter can use the back of his crow bar to hammer in nails, but there is a better way. It is important to understand that abrasive jets are not the same thing as the water jet although they are nearly the same. Water Jet technology has been around since the early 1970s or so, and abrasive jets extended the concept about ten years later. Both technology use the principle of pressuring water to extremely high pressure, and allowing the water to escape through opening typically called the orifice or jewel. Water jets use the beam of water exiting the orifice to cut soft stuffs like candy bars, but are not effective for cutting harder materials. The inlet water is typically pressurized between 20000 and 60000 Pounds Per Square Inch (PSI). This is forced through a tiny wall in the jewel which is typically .007" to .015" diameter (0.18 to 0.4 mm). This creates a vary high velocity beam of water. Abrasive jets use the same beam of water to accelerate abrasive particles to speeds fast enough to cut through much faster material.

COMPONENTS OF ABRASIVE JET MACHINING CENTER

The components of AJM centre include :

- Abrasive Delivery System
- Control System
- Pump
- Nozzle
- Motion System

2.1 Abrasive Delivery System

A simple fixed abrasive flow rate is all that's needed for smooth, accurate cutting. Modern abrasive feed systems are eliminating the trouble-prone vibratory feeders and solids metering valves of earlier systems and using a simple fixed-diameter orifice to meter the abrasive flow from the bottom of a small feed hopper located immediately adjacent to the nozzle on the Y-axis carriage. An orifice metering system is extremely reliable and extremely repeatable. Once the flow of abrasive through the orifice is measured during machine set-up, the value can be entered into the control computer program and no adjustment or fine-tuning of abrasive flow will ever be needed.

The small abrasive hopper located on the Y-axis carriage typically holds about a 45-minute supply of abrasive and can be refilled with a hand scoop while cutting is underway.

2.2 Control System

Fundamental limitation of traditional CNC control systems.

- Historically, water jet and abrasive jet cutting tables have used traditional CNC control systems employing the familiar machine tool "G-code." However, there is a rapid movement away from this technology for abrasive jet systems, particularly those for short-run and limited-production machine shop applications. G-code controllers were developed to move a rigid cutting tool, such as an end mill or mechanical cutter. The feed rate for these tools is generally held

constant or varied only in discrete increments for corners and curves. Each time a change in the feed rate is desired programming entry must be made. A

water jet or abrasive jet definitely is not a rigid cutting tool; using a constant feed rate will result in severe undercutting or taper on corners and around curves. Moreover, making discrete step changes in feed rate will also result in an uneven cut where the transition occurs. Changes in the feed rate for corners and curves must be made smoothly and gradually, with the rate of change determined by the type of material being cut, the thickness, the part geometry and a host of nozzle parameters.

The control algorithm that computes exactly how the feed rate should vary for a given geometry in a given material to make a precise part. The algorithm actually determines desired variations in the feed rate every 0.0005" (0.012 mm) along the tool path to provide an extremely smooth feed rate profile and a very accurate part. Using G-Code to convert this desired feed rate profile into actual control instructions for the servo motors would require a tremendous amount of programming and controller memory. Instead, the power and memory of the modern PC can be used to compute and store the entire tool path and feed rate profile and then directly drive the servomotors that control the X-Y motion. This results in a more precise part that is considerably easier to create than if G-code programming were used.

2.3 Pump: Intensifier pumps

Early ultra-high pressure cutting systems used hydraulic intensifier pumps exclusively. At the time, the intensifier pump was the only pump capable of reliably creating pressures high enough for water jet machining. An engine or electric motor drives a hydraulic pump which pumps hydraulic fluid at pressures from 1,000 to 4,000 psi (6,900 to 27,600 kPa) into the intensifier cylinder. The hydraulic fluid then pushes on a large piston to generate a high force on a small-diameter plunger. This plunger pressurizes water to a level that is proportional to the relative cross-sectional areas of the large piston and the small plunger.

Crankshaft pumps

The centuries-old technology behind crankshaft pumps is based on the use of a mechanical crankshaft to move any number of individual pistons or plungers back and forth in a cylinder. Check valves in each cylinder allow water to enter the cylinder as the plunger

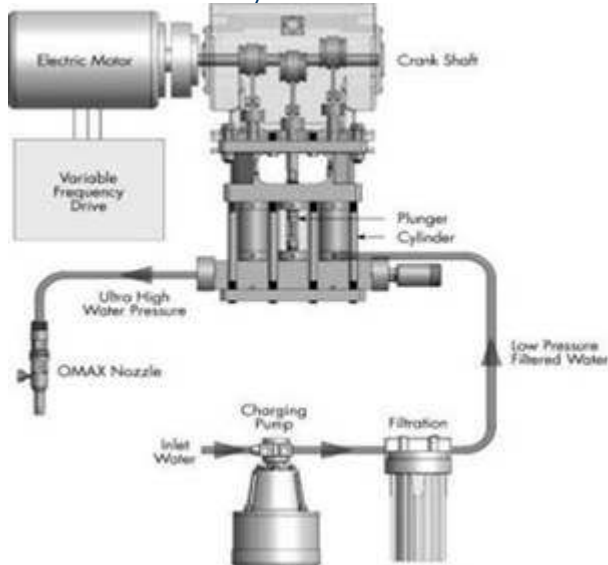

fig:2 (crankshaft pump)

retracts and then exit the cylinder into the outlet manifold as the plunger advances into the cylinder. Crankshaft pumps are inherently more efficient than intensifier pumps because they do not require a power-robbing hydraulic system. In addition, crankshaft pumps with three or more cylinders can be designed to provide a very uniform pressure output without needing to use an attenuator system. Crankshaft pumps were not generally used in ultra-high pressure applications until fairly recently. This was because the typical crankshaft pump operated at more strokes per minute than an intensifier pump and caused unacceptably short life of seals and check valves. Improvements in seal designs and materials, combined with the wide availability and reduced cost of ceramic valve components, made it possible to operate a crankshaft pump in the 40,000 to 50,000 psi (280,000 to 345,000 kPa) range with excellent

reliability. This represented a major breakthrough in the use of such pumps for abrasive jet cutting.



Typical 20/30 horsepower crankshafts driven triplex pump.

Experience has shown that an abrasive jet does not really need the full 60,000 psi (414,000 kPa) capability of an intensifier pump. In an abrasive jet, the abrasive material does the actual cutting while the water merely acts as a medium to carry it past the material being cut. This greatly diminishes the benefits of using ultra-high pressure. Indeed many abrasive jet operators with 60,000 psi (414,000 kPa) intensifier pumps have learned that they get smoother cuts and more reliability if they operate their abrasive jets in the 40,000 to 50,000 psi (276,000 to 345,000 kPa) range. Now that crankshaft pumps

produce pressures in that range, an increasing number of abrasive jet systems are being sold with the more efficient and easily maintained crankshaft-type pumps.

2.4 Nozzles

All abrasive jet systems use the same basic two-stage nozzle as shown in the FIG. First, water passes through a small-diameter jewel orifice to form a narrow jet. The water jet then passes through a small chamber where a Venturi effect creates a slight vacuum that pulls abrasive material and air into this area through a feed tube. The abrasive particles are accelerated by the moving stream of water and together they pass into a long, hollow cylindrical ceramic mixing tube. The resulting mix of abrasive and water exits the mixing tube as a coherent stream and cuts the material. It's critical that the jewel orifice and the mixing tube be precisely aligned to ensure that the water jet passes directly down the center of the mixing tube. Otherwise the quality of the abrasivejet will be diffused, the quality of the cuts it produces will be poor, and the life of the mixing tube will be short.

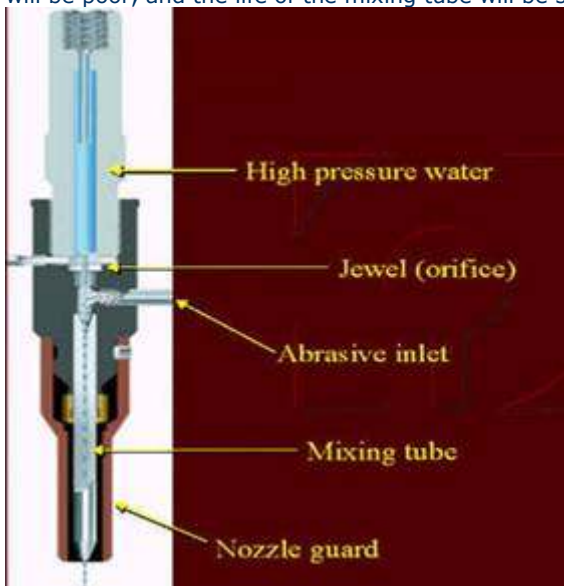

FIG: Typical abrasivejet nozzle

The typical orifice diameter for an abrasive jet nozzle is 0.010" to 0.014" (0.25 mm to 0.35 mm). The orifice jewel may be ruby, sapphire or diamond, with sapphire being the most common.. The venturi chamber between the jewel orifice and the top of the mixing tube is an area that is subject to wear. This wear is caused by the erosive action of the abrasive stream as it enters the side of the chamber and is entrained by the waterjet. Some nozzles provide a carbide liner to minimize this wear. Precise alignment of the jewel orifice and the mixing tube is critical to mixing tube life. This is particularly true for the relatively small diameter 0.030" (0.75 mm).

Mixing Tube

The mixing tube is where the abrasive mixes with the high-pressure water. The mixing tube should be replaced when tolerances drop below acceptable levels. For maximum accuracy, replace the mixing tube more frequently. The size of the kerf and cutting performance are the best indicators of mixing tube wear.

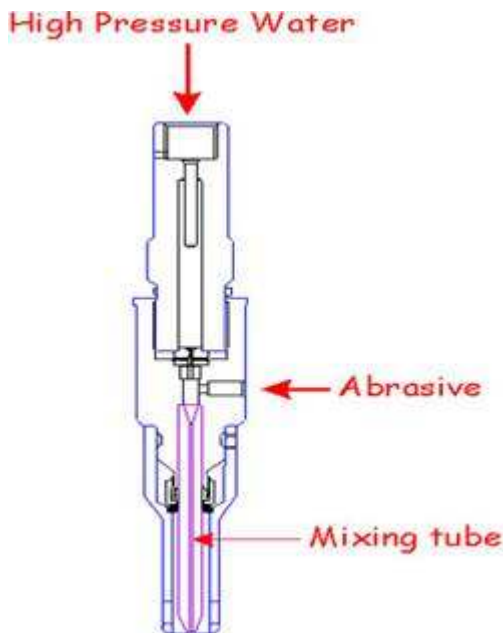

Fig: Mixing Tube

2.5 Motion System :

X-Y Tables

In order to make precision parts, an abrasivejet system must have a precision X-Y table and motion control system. Tables fall into three general categories:

- Floor-mounted gantry systems with separate cutting tables
- Integrated table/gantry systems
- Floor-mounted cantilever systems with separate cutting tables

Each type of system has its benefits and drawbacks.

1. Floor-mounted gantry with separate cutting table

A floor-mounted gantry with a separate cutting table is the most common approach used by waterjet system manufacturers. A framework that supports the X-Y motion system is secured directly to the floor and straddles a separate cutting table and catcher tank. The nozzle(s) is mounted to a carriage which moves along a gantry beam that straddles the table. The gantry beam is supported on each end by a guide system and is moved by ball screws, rack and pinion assemblies or drive belts located at each end. The parallel drive mechanisms are either operated by two electronically-coupled drive motors or by a single motor driving a mechanically-coupled drive system.

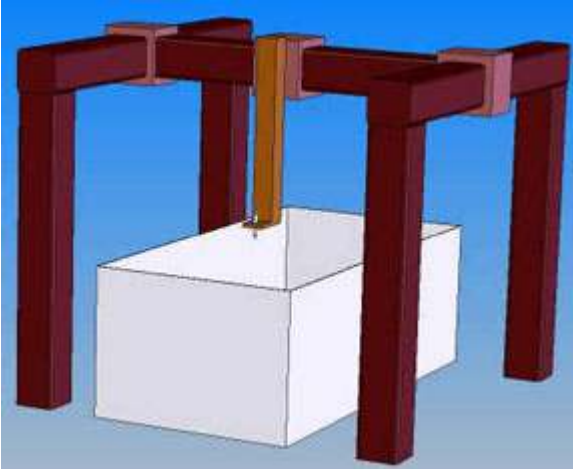

2.Integratedtable/gantrysystem

The integrated table/gantry system is very similar to the traditional gantry system previously described, except that the guides for the gantry beam are integrated into the cutting table. Because of this the X-Y motion system and the material support table are part of the same overall structure and unwanted relative motion between them is eliminated. In this type of system, the floor is not a vital part of the system structure. This system is typically more accurate than the more traditional separate gantry and table.

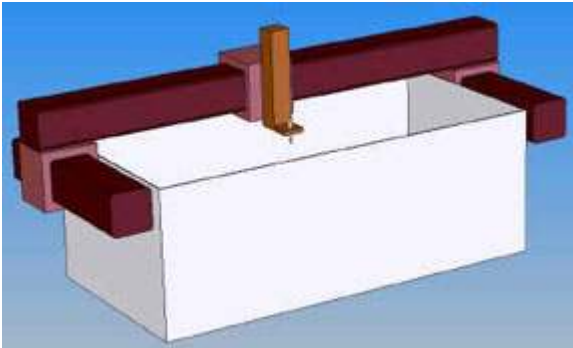

Integrated table/gantry system.

3.Floor-mounted cantilever system with separate cutting table

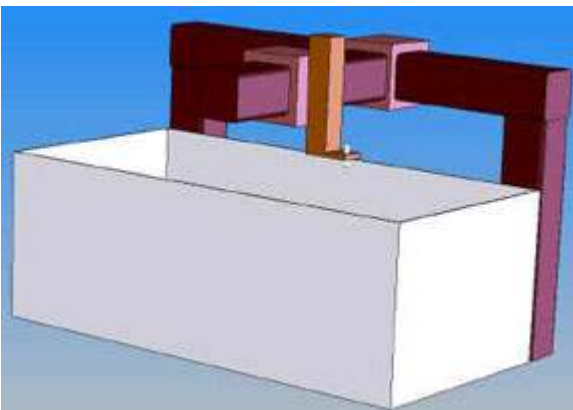

MESA

This type of system uses a floor-mounted X-axis and a cantilevered Y-axis mounted to the X-axis carriage. The nozzle mounts to a carriage on the Y-axis. The cutting table is totally separate from the X-Y motion structure.

3.WORKING

A typical abrasive jet machining center is made up of the following components:

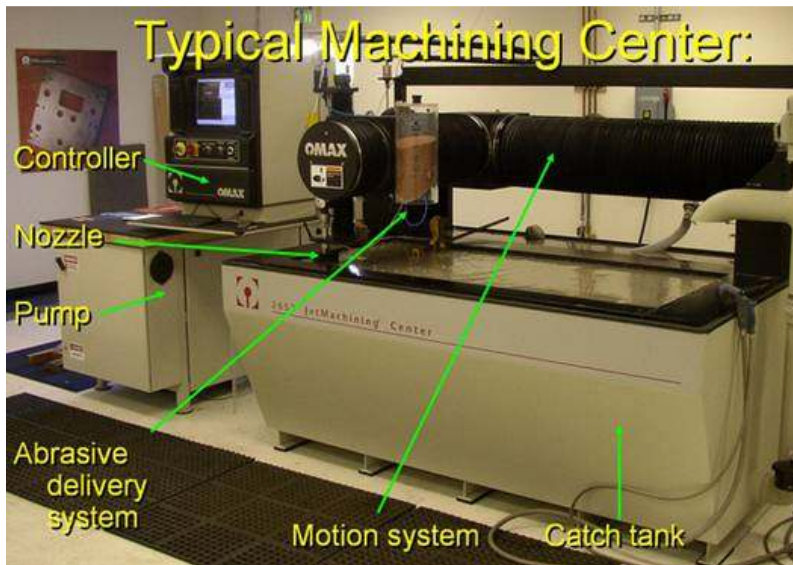

High pressure water starts at the pump, and is delivered through special high pressure plumbing to the nozzle. At the nozzle, abrasive is (typically) introduced, and as the abrasive/water mixture exits, cutting is performed. Once the jet has exited the nozzle, the energy is dissipated into the catch tank, which is usually full of water and debris from previous cuts. The motion of the cutting head is typically handled by an X / Y-axis structure. Control of the motion is typically done via a computer following the lines and arcs from a CAD drawing.

4.AJM FEATURES

(A)Obtainable tolerances:

You need a machine with good precision to get precision parts, but there are many other factors that are just as important. A precise machine starts with a precise table, but it is the control of the jet that brings the precision to the part. **A key factor in precision is software** - not hardware. This is also true for cutting speed. Good software can increase cutting speeds dramatically. This is because it is only through sophisticated software that the machine can compensate for a "floppy tool" made from a stream of water, air, and abrasive.

Obtainable tolerances vary greatly from manufacturer to manufacturer. Most of this variation comes from differences in controller technology, and some of the variation comes from machine construction. Significant advances are made in the control of the process allowing for higher tolerances.

(B)Material to machine

Harder materials typically exhibit less taper, and taper is a big factor in determining what kind of tolerances you can hold. It is possible to compensate for taper by adjusting the cutting speed, and/or tilting the cutting head opposite of the taper direction.

(C)Material thickness

As the material gets thicker, it becomes more difficult to control the behavior of the jet as it exits out the bottom. This will cause blow-out in the corners, and taper around curves. Materials thinner than 1/4" (6mm) tend to exhibit the most taper (which is perhaps the opposite of what you might expect.), and with thicker materials, the controller must be quite sophisticated in order to get decent cuts around complex geometry.

(D)Accuracy of table

Obviously, the more precise is the positioning the jet, the more precise will be the machine part.

(E)Stability of table

Vibrations between the motion system and the material, poor velocity control, and other sudden variances in conditions can cause blemishes in the part ("witness marks"),
The hardware that is out there varies greatly in stability and susceptibility to vibrations. If the cutting head vibrates relative to the part, the part will be ugly.

(F)Control of the abrasive jet

Because your cutting tool is basically a beam of water, it acts like a "floppy tool". The jet lags between where it first enters your material and where it exits.

5. MACHINING ASPECTS

1. Around curves

As the jet makes its way around a radius, the jet down, and let the tail catch up with the head. (And / or tilt the cutting head to compensate)

2. Inside corners

As the jet enters the corner, the traverse speed must slow down to allow the jets tail to catch up. Otherwise the tail lag will cause the corner to "blow out" a little.
As the jet exits the corner, the feed rate must not be increased too quickly, otherwise the jet will kick back and damage the part.

3. Feed rate:

When the jet slows down, its kerf width grows slightly.

4. Acceleration:

Any sudden movement (like a change in feed rate) will cause a slight blemish as well. Thus for highest

precision it is necessary to control the acceleration as well as feed rate.

5.Nozzle Focus

Some nozzles produce more taper than others. Longer nozzles usually produce less taper. Smaller diameter nozzles also produce less taper. Holding the nozzle close to the work piece produces less taper as well.

6.Speed of cutting

Typically, the slower the cutting, the higher the tolerance. This is because as the cutting is slowed down, the surface finish improves, and the taper begins to disappear. However in some cases it is possible to slow the cutting down so much that tolerances begin to get worse due to reverse taper.

7.Active taper compensation

Some newer machines now have the option of tilting the cutting head against the taper. This can be used to virtually eliminate the taper, or to purposely add taper into a part. The big advantage to active taper compensation is that taper can be reduced without having to slow the cutting down. ("Taper" is when the edge of the part is not 100% perpendicular.) I have an entire page dedicated to this topic elsewhere in this web site. If you want to go there now.

8.Kerf width

Kerf width, which is the width of the cutting beam, determines how sharp of an inside corner you can make. About the smallest practical abrasive jet nozzle will give you a kerf width of .020" (0.5mm) in diameter. Higher horsepower machines require larger nozzles, due to the amount of water and abrasive that they flow through.

Some water jet (water only) nozzles have very fine kerf widths (like .003" / 0.076mm). Likewise, it is possible to make ultra-small abrasive jet nozzles, but they are problematic.

9.Consistency of Pump Pressure

Variations in water jet pump pressure can cause marks on the final part. It is important that the pump pressure vary as little as possible while machining is in progress to prevent these. (This becomes an issue only when looking for better than $\pm .005$ " (0.125mm) tolerances, however). Typically it is older Intensifier type pumps that exhibit this problem. Some newer intensifiers, and as far as I know all crankshaft driven pumps have smoother pressure delivery, and this is not an issue.

10.Cutting speeds:

Ideally, you want to make the most precise part possible in the least amount of time, and for the least amount of money. Cutting speeds are a function of the the material to cut, the geometry of the part, the software and controller doing the motion, the power and efficiency of the pump making the pressure, and a few other factors such as the abrasive used:

Here are the primary factors that determine cutting speed:

Material being cut (And how thick it is)

Hardness: Generally speaking, harder materials cut slower than soft materials. However, there are a lot of exceptions to this. For example, granite, which is quite hard, cuts significantly faster than Copper, which is quite soft. This is because the granite easily breaks up because it is brittle. It is also interesting to note that hardened tool steel cuts almost as quickly as mild steel. (Though "absolute black" granite, which is tough as nails, actually cuts a bit slower than copper.)

Thickness: The thicker the material, the slower the cut. For example, a part that might take 1 minute in 1/8" (3mm) steel, might take a half hour in 2" (50mm) thick steel, and maybe 20 hours in 10 inch (250mm) thick steel.

Geometry of the part

It is necessary to slow the cutting down in order to navigate sharp corners and curves. It also takes additional time to pierce the material. Therefore, parts with lots of holes and sharp corners will cut much slower than simpler shapes.

Desired Result

If you want a high tolerance part and / or a smooth surface finish, then the part will take longer to make. Note that you can make some areas of a part high tolerance and other areas fast, so you can mix and match to get the optimal balance between cutting speed and final part quality.

Software controlling the motion

This is probably one of the most overlooked aspects of abrasive jet machining by novice users. You would not think that software would have much to do with the speed of cutting. In fact, this is true if all you are doing is cutting in a straight line. However, as soon as you introduce any complexity to the part, such as a corner, there is great opportunity for software to optimize the cutting speed.

The difference, as it turns out, is all through software that automatically optimizes the tool path to provide the desired precision in the least amount of time. Basically, what the software does, is looks at the geometry of the part, and then modify the feed rates and add "tweaks" to the cutting in order to squeeze the maximum amount of speed. It does this by finding the optimal speeds and accelerations for all curves and corners, setting the optimal length and feed rate for all pierce points, adding special "corner pass" elements at corners to allow the cutting to go right past the corners where it can, etc.

It was found that by simply optimizing the corners that we could get about a factor of two in cutting speed over a hand-optimized part. Then, over the next 10 years or so, we added a lot more optimizations in terms of faster piercing, corner passing, improved cutting models and such, and were able to get another factor of 2 in cutting speed for some parts, while at the same time increasing the precision.

So, software matters! And one of the most beautiful things about optimizing in software is that it does not cost any money. In fact, it saves money, because if you cut faster through software, you use less abrasive and put less wear and tear on all the high-pressure components!

Power at the nozzle (pressure and water flow rate)

The more horsepower at the nozzle, the faster you can cut. How much horsepower makes it to the nozzle is a function of the pressure and the orifice that it's being squeezed through. (Note: do not confuse "horsepower" with "horsepower at the nozzle". It is the power that actually makes it to the nozzle that is most important. Having a big motor makes no difference, if the power all goes into wasted heat!)

Simply put, the higher the pressure, the faster the cut. The more water you flow, the faster the cut. Unfortunately, as the pressure increases, so does the cost and maintenance, so this is not as simple as it seems.

A good way to learn more about how pressure and jewel size effect-cutting rates, and to calculate "nozzle horsepower" is to run the Abrasive jet Feed Rate Calculator, which you can download from this web site.

Type of abrasive: In the industry, pretty much everyone uses 80 mesh garnet for their abrasive. However, it is possible to cut slightly faster with harder abrasives. However, the harder abrasives also cause the mixing tube on the nozzle to wear rapidly. So, pretty much everyone uses garnet. It is worth mentioning that not all garnet is the same. There are big variations between purity, hardness, sharpness, etc, that can also effect the cutting speed and operating cost.

Quality of abrasive:

Typically, abrasive jets consume between 0.5 and 1 Lb (0.25 and 0.5Kg) of abrasive per minute. There is a sweet spot for every nozzle size and pressure as to what amount of abrasive flow rate will cut the fastest, and what amount will cut the cheapest.

6.COMPARISON TO OTHER MACHINING PROCESSES

1.Comparison with EDM

Key Wire EDM strengths

- Extremely precise parts are possible [± 0.0001 " (± 0.025 mm)]
- Very thick parts [over 12" (30 cm)] can be made
- Intentional taper can be put into a part for die clearance and other uses

Key Precision Abrasive jet strengths

- Five to ten times faster in parts less than 1" (2.5 cm) thick [but, at ± 0.003 " (± 0.1 mm), less precise as well
- No Heat Affected Zone (HAZ), so no need for secondary operations to remove the HAZ or additional heat-treating to compensate for it
- Works well in non-conductive materials (such as glass, stone, plastic) as well as conductive materials
- Can pierce material directly without the need for a pre-drilled starter hole
- Can produce large parts at reasonable costs
- Simple and rapid programming and set-up with minimal fixturing

2.Comparing abrasive jet to laser

Key laser strengths

- Very fast production in thin, non-reflective materials such as sheet steel.
- Accuracy to ± 0.001 " (± 0.025 mm) or better in thin material.

Key precision abrasive jet strengths

- Can produce parts up to 2" (5.1 cm) thick in virtually any material while holding tolerances on the order of ± 0.003 " to ± 0.005 " (± 0.08 to ± 0.1 mm).
- Can machine reflective, conductive and thicker materials such as stainless steel and aluminum, copper and brass.
- Cuts without melting, providing a smooth uniform surface with very little burr or dross.
- No heat-affected zone (HAZ), which may eliminate the need for a secondary operation to remove HAZ and makes conventional secondary operations, such as reaming or tapping, easier to perform.
- No noxious gas or vapors produced during cutting.
- Simple and rapid programming and set-up for short-run parts.

3.Comparison of precision abrasive jet to milling

Key mill or machining center strengths

- A well-understood familiar technology.
- Able to make three-dimensional parts.
- Rapid production if set up and programmed for long-run parts.

Key precision abrasive jet strengths

- Very rapid programming and set-up does not require a highly trained operator.
- Very low cutting loads means that fixturing is easier and also means that intricate and delicate parts can be machined.
- One cutting tool performs all machining functions in all materials, so there is no need to purchase and calibrate multiple cutting tools.
- Large cutting envelope compared to a machining center of comparable price.

- Minimal burr compared to conventional machining.
Environmentally friendly; no oil-soaked chips and minimal scrap.
- The key reasons traditional job shops buy a precision abrasivejet is to get new projects, become more competitive, and make more money.

4. Comparison of precision abrasive jet to milling

Key mill or machining center strengths

- A well-understood familiar technology.
- Able to make three-dimensional parts.
- Rapid production if set up and programmed for long-run parts.

Key precision abrasive jet strengths

- Very rapid programming and set-up does not require a highly trained operator.
- Very low cutting loads means that fixturing is easier and also means that intricate and delicate parts can be machined.
- One cutting tool performs all machining functions in all materials, so there is no need to purchase and calibrate multiple cutting tools.
- Large cutting envelope compared to a machining center of comparable price.
- Minimal burr compared to conventional machining.
Environmentally friendly; no oil-soaked chips and minimal scrap.
- The key reasons traditional job shops buy a precision abrasive jet is to get new projects, become more competitive, and make more money.

7. MACHINABLE MATERIALS

Virtually any material can be cut by using AJM method i.e. harder materials like titanium to steel
 Aluminum, Steel, Titanium Laminates
 Flammable materials
 Cut thin stuff, or thick stuff
 Brittle materials like glass, ceramic, quartz, stone.
 Laminates
 Flammable materials
 Cut thin stuff, or thick stuff

8. PROCESS ADVANTAGES & LIMITATIONS:

ADVANTAGES OF ABRASIVE JET:

(a) Extremely fast setup and programming

No tool changes required, so there is no need to program tool changes or physically qualify multiple tools. For some systems, programming simply involves drawing the part. If your customer gives you that drawing on disk, half the battle is won.

This means that (for some machines) you can make good money off single part and low volume production!

(b) Very little fixturing for most parts

Flat material can be positioned by laying it on the table and putting a couple of 10 lb weights on it. Tiny parts might require tabs, or other fixturing. At any rate, fixturing is typically not any big deal.

Machine virtually any 2D shape (and some 3D stuff)

Including tight inside radii, Make a carburetor flange with holes drilled and everything.

(c)Very low side forces during the machining

This means you can machine a part with walls as thin as .025" (0.5 mm) without them blowing out. This is one of the factors that make fixturing is so easy. Also, low side forces allow for close nesting of parts, and maximum material usage.

(d)Almost No heat generated on your part

You can machine without hardening the material, generating poisonous fumes, recasting, or warping. You can machine parts that have already been heat treated with only a tiny, tiny decrease in speed. On piercing 2" (50mm) thick steel, temperatures may get as high as 120 degrees F (50 C), but otherwise machining is done at room temperature.

Aerospace companies use abrasive jets a lot because of this.

(e)No start hole required

Wire EDM, eat your heart out. Start holes are only required for impossible to pierce materials. (Some poorly bonded laminates are about the only materials I can think of off hand)

(f)Machine thick stuff

This is one huge advantage Abrasive jets have over lasers.

While most money will probably be made in thickness' under 1" (25mm) for steel, It is common to also machine up to 4" (100mm). I don't know the actual limit to thickness, but cutting speed is a function of thickness, and a part twice as thick will take more than twice as long. I have heard of people making low tolerance parts and roughing out metal up to 5-10" thick (125mm-250mm), but those people are very patient, and probably have no other way to do it. Typically, most money is made on parts 2" (50mm) thick or thinner.

(g)Environmentally friendly

Green Peace does not like some of those other tools in your shop. Not much of an issue now, but in the future I would expect the pressure will be on. Short of hand tools, abrasive jets provide the most environmentally friendly machining around. (Some of the pumps even use vegetable oil for assembly lube because water jets are used in the food industry).

As long as no hazardous material is machined, the spent abrasive and waste material become suitable for landfill. The red color of garnet abrasive also looks nice in your garden. If lots of lead or other hazardous materials are machined, you will still need to dispose of your waste appropriately, and recycle your water. Very little metal is actually removed in the cutting process. This keeps the environmental impact relatively low, even if you do machine the occasional hazardous material.

(h)Your clippings are valuable

When machining or roughing out expensive materials such as titanium, your scrap still has value. This is because you get chunks, not chips. You can also get more parts from the same material because of the abrasive jets low kerf width.

(i)There is only 1 tool

There is no need to qualify multiple tools, or deal with programming tool changes. Programming, Setup and Clean up time is reduced significantly, meaning you make more money because you can turn more parts faster.

LIMITATIONS OF ABRASIVE JET:

- Despite their simple design, abrasive jet nozzles can be troublesome at times. There are many designs, but they share the same problems:
 - Short life of an expensive wear part: The mixing tube. Like I said, the abrasive jet can cut through just about anything - including itself. This will be a large part of your operating cost. (More on operating cost later)
- Occasional plugging of mixing tube: Usually caused by dirt or large particles in abrasive. (This used to be a big problem with abrasive jet nozzles, but not so much any more.)
- Wear, misalignment, and damage to the jewel.

9.CONCLUSION

The better performance, and the applications presented above statements confirm that **ABRASIVE JET MACHINING (AJM)** will continue to expand. Industry is convinced that the large aerospace segment will take off in near the future, together with other segments that are currently showing interest in AJM method. From operator experiences the abrasive jets are capable of anywhere from 0.5mm-0.025mm precision. High precision manufacturing needs can be met by using AJM method. Newer machines are capable of 3D machining thus making it an important in specialty manufacturing. The new software's used will minimize time and investments, thereby making it possible for more manufacturers of precision parts to install AJM centers.

REFERENCES

1. Processes and Materials of Manufacture by R.A. LINDBERG
2. SEMINAR TOPIC FROM :: www.edufive.com/seminartopics.html
3. www.pcmag.com/encyclopedia